

MT Series

Discrete Element, Micro-Miniature Lowpass Filters

Microwave Filter Company's MT series of Lowpass filters offer superior performance in a small package for a wide range of applications.

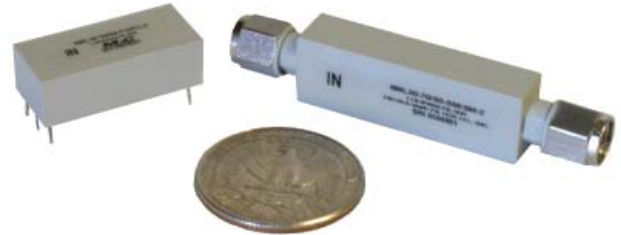

FEATURES:

- Available frequency range: 500 MHz to 6000 MHz
- Micro-Miniature package
- 3-9 section designs are standard
- Call the factory for custom designs

SPECIFICATIONS

Model No.	Frequency (MHz)	VSWR typical	Average Power (Watts, nominal)	Impedance (ohms)	No. of Sections
MT10	500-6000	1.5:1	1	50	3-9

MODEL DESIGNATION

Code	Description
1	Number of Sections
2	Model Number
3	Start of Stopband Frequency (MHz)
4	3dB Cut -off Frequency (MHz)
5	Connector Code (Input/Output)
6	Mechanical Outline (Style)

CONNECTOR CODE CHART

Connector Style	Connector Code
SMA Female	SF
SMA Male	SM
PC Pins	PN
Special	XX

SAMPLE

<u>8</u>	<u>MT10-</u>	<u>2000/</u>	<u>1600-</u>	<u>PN/PN-</u>	<u>1</u>
1	2	3	4	5	6

6743 KINNE STREET

E. SYRACUSE, NY 13057

800-448-1666 • 315-438-4700

E-Mail: mfcsales@microwavefilter.com

Web: www.microwavefilter.com

MT Series Discrete Element, Micro-Miniature Lowpass Filters

Selectivity- The stopband performance of a filter determines the number of sections required.
Use the following graph.

The graph provides the lowpass filter stopband attenuation as a function of the number of filter sections and the stopband frequency F_s normalized to the 3dB cutoff frequency $F_{-3\text{dB}}$

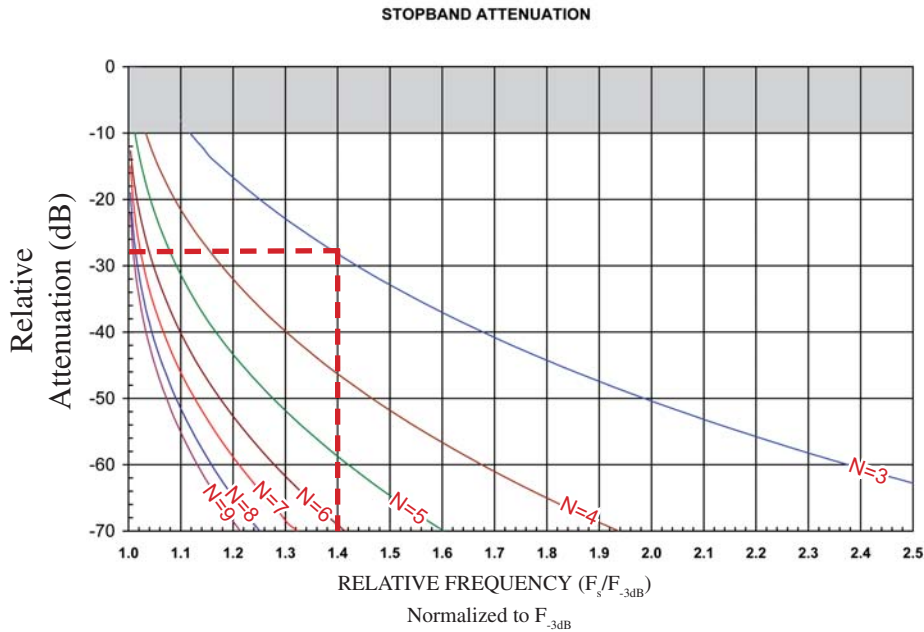

EXAMPLE

Determine the number of sections required to achieve an attenuation of 30 dB at 2800 MHz (F_s) with a 3 dB cutoff frequency ($F_{-3\text{dB}}$) of 2000 MHz

- 3dB Cutoff Frequency, $F_{-3\text{dB}} = 2000$ MHz
- Stopband rejection frequency $F_s = 2800$ MHz
- Attenuation value of stopband= 30dB

Step 1. Normalize stopband frequency (F_s) to the -3 dB cutoff frequency $F_{-3\text{dB}}$

$$\frac{F_s}{F_{-3\text{dB}}} = \frac{2800\text{MHz}}{2000\text{MHz}} = 1.4$$

Step 2. Determine the minimum number of sections required to provide a stopband attenuation equal to or greater than 30dB.

Note from the intersection of 1.4 on the X- axis and curve N=4 the attenuation (Y-axis) is -46 dB and N=3 is approx -28dB. Therefore the minimum number of sections required is N = 4

*Note: For illustration purposes only. Consult factory for specific information.

MT Series

Discrete Element, Micro-Miniature Lowpass Filters

STYLE 1 CONNECTORS

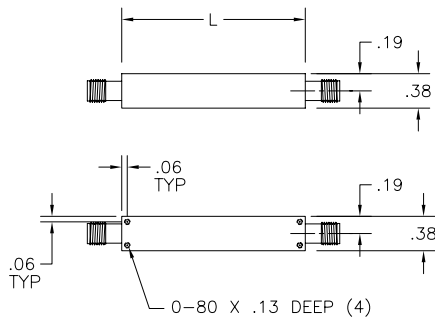

STYLE 1 PINS

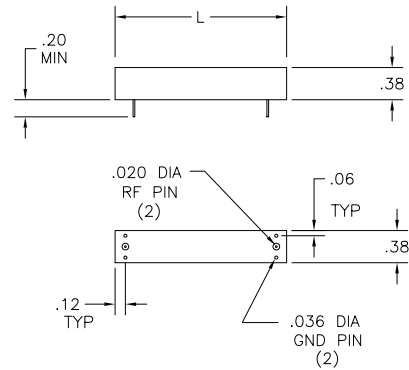

STYLE 2 CONNECTORS

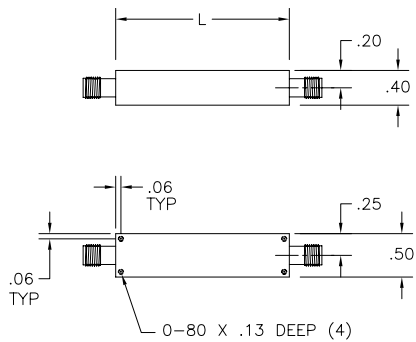

STYLE 2 PINS

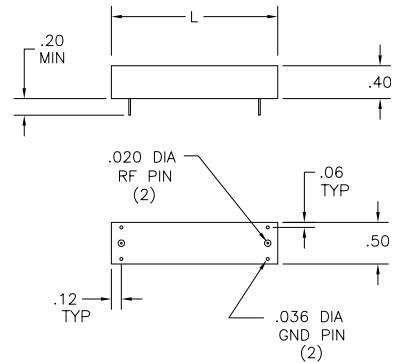

Model	Number of Sections	Style	Width (IN.)	Height (IN.)	Length (IN.)
MT Series	3	1	0.38	0.38	0.75
MT Series	4-5	1	0.38	0.38	1.0
MT Series	6-7	2	0.50	0.40	1.5
MT Series	8-9	2	0.50	0.40	1.75

6743 KINNE STREET
E. SYRACUSE, NY 13057
800-448-1666 • 315-438-4700

E-Mail: mfcsales@microwavefilter.com
Web: www.microwavefilter.com